

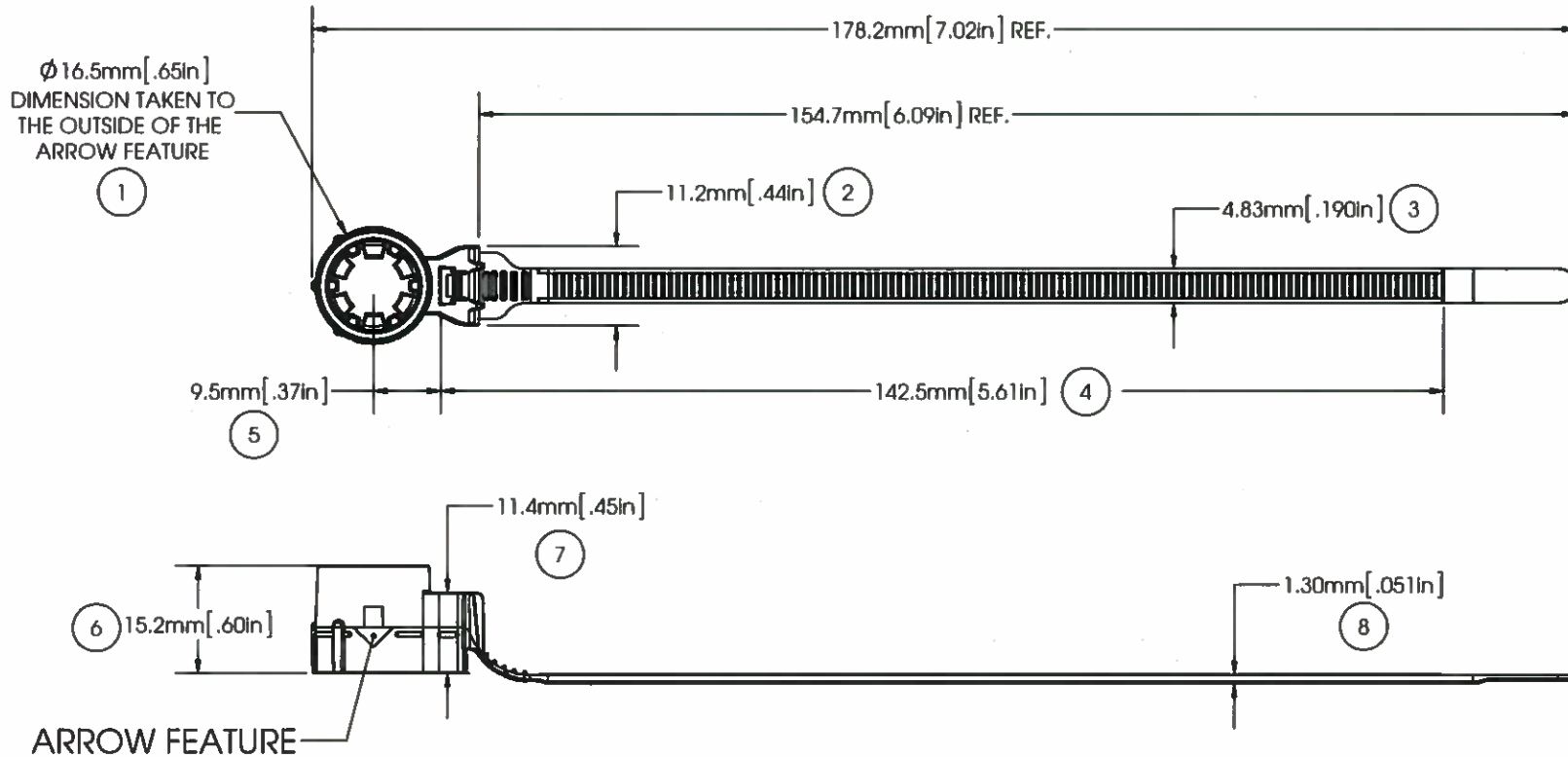

# AVERY DENNISON MARKETING SPECIFICATION

## HISTORY

| REV. | DATE     | DESCRIPTION |
|------|----------|-------------|
| A    | 01.23.15 | RELEASED    |

THE SUBJECT MATTER DISCLOSED HEREIN EMBODIES PROPRIETARY INFORMATION WHICH IS THE CONFIDENTIAL PROPERTY OF THE AVERY DENNISON CO. NONE OF WHICH SHALL BE COPIED, REPRODUCED, DISCLOSED TO OTHERS, PUBLISHED OR USED IN WHOLE OR IN PART, FOR ANY PURPOSE OTHER THAN THAT FOR WHICH IT IS BEING MADE AVAILABLE WITHOUT THE EXPRESS ADVANCE WRITTEN PERMISSION OF A DULY AUTHORIZED AGENT OF THE COMPANY. THIS DOCUMENT IS THE PROPERTY OF THE AVERY DENNISON CO. AND IS TO BE RETURNED TO THE COMPANY ON DEMAND.



|                       |                                                                                       |                           |                                       |                                                                                                                                                                                                                                                                                             |
|-----------------------|---------------------------------------------------------------------------------------|---------------------------|---------------------------------------|---------------------------------------------------------------------------------------------------------------------------------------------------------------------------------------------------------------------------------------------------------------------------------------------|
| MOUNTING:             | M10 X 1.25 and M10 X 1.5 STUDS                                                        | APPROVALS:                | ENG. APPR. <i>[Signature]</i> 1/23/15 |  <b>AVERY DENNISON</b><br><small>FASTENER DIVISION<br/>                     FITCHBURG, MA 01420 U.S.A.<br/>                     TEL. 1-800-225-5913<br/>                     FAX. 978-353-8157</small> |
| TENSILE STRENGTH:     | 50 LBF / 222N MIN.                                                                    |                           | Q.A. APPR. <i>[Signature]</i> 1/23/15 |                                                                                                                                                                                                                                                                                             |
| WEIGHT:               | 2.7g                                                                                  | SPECIFIED TOLERANCES ARE: |                                       | MATERIAL<br><b>NYLON 6/6,<br/>                 IMPACT MODIFIED, HEAT STABILIZED</b>                                                                                                                                                                                                         |
| TEMPERATURE RANGE:    | -40°F (-40°C) TO 239°F (115°C)<br>CONTINUOUS AND 257°F (125°C)<br>AT MAXIMUM EXPOSURE | .XX ± .03 INCHES          | .X ± .7 mm                            |                                                                                                                                                                                                                                                                                             |
| BUNDLE DIAMETER:      | Ø 1.6mm TO Ø 38.1mm                                                                   | .XXX ± .010 INCHES        | .XX ± .25 mm                          | STOCK NO.<br><b>20153-0</b>                                                                                                                                                                                                                                                                 |
| TOOL:                 | 12001- HAND INSTALLATION TOOL<br>12500- PNUM. INSTALLATION TOOL                       | ANGULAR: ± 2°             |                                       |                                                                                                                                                                                                                                                                                             |
| TOOL TENSION SETTING: | 6 - 8                                                                                 |                           |                                       |                                                                                                                                                                                                                                                                                             |
| PACKAGING:            | 1000/BAG, 5 BAGS/MASTER                                                               |                           |                                       |                                                                                                                                                                                                                                                                                             |

5

4

3

2

1